

# Konecranes Noell Straddle Carriers



**NEW!** Redesigned in a completely modular fashion around swappable power options

**WITH ALL POWER OPTIONS!**

- Hybrid
- Battery
- Hydrogen
- Future power



# Konecranes Noell Straddle Carrier at a glance

## Power up for the future

We have improved this straddle carrier steadily over the years, and now offer this workhorse machine with a new design based on modularity. You can select hybrid power now with built-in readiness for battery and hydrogen. Retrofitting another power option will be easy down the road. Meanwhile, you get many technical improvements with no need for infrastructure upgrades. Available in versions stacking containers 1-over-2 and 1-over-3, ideally suited for step-by-step enlargement of container terminals as needed.

### CABIN

- Large double glass windows for good all-round visibility
- Brake-by-wire and steer-by-wire
- Better insulation, heat pump for cooling and heating for more operator comfort and less energy usage
- Ergonomically designed, adjustable driver seat and controls
- Optional: electrically rotating seat
- Intuitive GUIs

### KONECRANES NOELL SPREADERS

- Single-lift, twin-lift and separating twin-lift
- Soft landing function on container and low maintenance guides
- Automatic movement to preset positions (20', 30', 40')
- Telescoping cylinders hydraulically locked in position: patented solution, no locking pins
- Optional automatic spreader positioning system (ASPS) and set-down function

### TRUCONNECT

- Systems can be monitored remotely, enabling fleet managers to optimize operations, adjust routes in real-time, and troubleshoot problems without a technician on-site
- Machine data can be accessed through our customer portal or direct to your systems
- Pre-installed on all new machines, activated upon agreement

### POWER OPTIONS

- Hybrid
- Battery
- Hydrogen
- Future power options

### MACHINERY PLATFORM, EASY ACCESS

- Designed for all existing power options: hybrid, battery, hydrogen
- Each power option is retrofittable and interchangeable
- Easy access to engine, generator, hydraulics, electrical panels, hoisting motor/winches
- Powertrain can be fitted with a sound-dampening sliding cover: still easy access

### HOISTING SYSTEM

- Maximum lifting capacity 60t
- Rope drums driven and synchronized by centrally positioned electric motor
- Maintenance-free, three-phase AC motor
- Small number of rope pulleys for low rope wear
- Overload protection

### STEEL STRUCTURE

- Sleek, lightweight with diagonal braces giving optimized visibility
- Optimum balance of flexibility and long life
- Sill beam tough yet lightweight, made from a single piece of sheet metal to reduce welding
- Yoke beam guided by low-maintenance sliding pads in the portal
- Power and hydraulic supply to spreader provided via pantograph or chain, robust, few joints, few spare parts

### WHEEL SUSPENSION AND DRIVES

- Good load distribution thanks to eight individually suspended wheels
- Wheel suspension and drives with maintenance-free spring system
- Four wheels are driven: direct drive via wheel hub motors
- Maintenance-free, three-phase AC motors
- Maintenance-free wet disk brakes
- Wheels individually steered by central steering cylinders and rods
- Plastic wheel cover fender, doesn't rust, doesn't lose form easily



Hybrid, battery, hydrogen, future power

# Power up for the future

## Hybrid

The Hybrid Konecranes Noell Straddle Carrier is very popular with container terminal customers: we have sold many units in the last two years. Hybrid straddle carrier operation is an important step on the Ecolifting road.

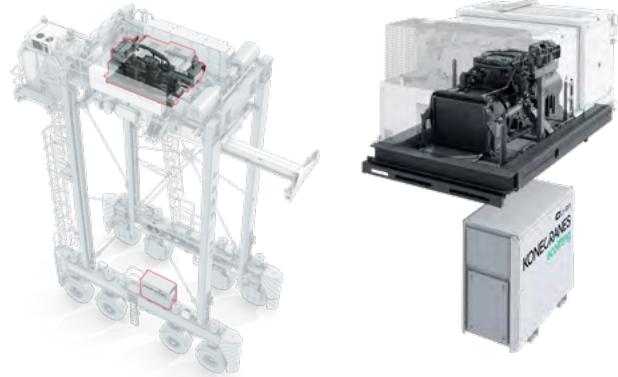

## Battery

The Battery Konecranes Noell Straddle Carrier can be adopted easily by brownfield container terminals without major yard adjustments. The charging station can be placed in a maintenance area for convenient access. Charging sessions can be designed as part of smooth work cycles.

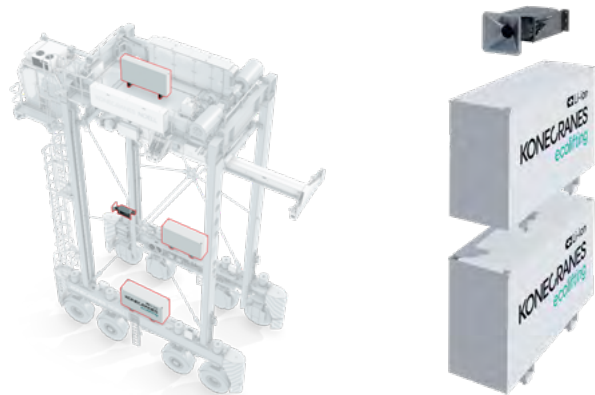

## Hydrogen

Hydrogen is emerging as an alternative fuel for straddle carriers. Hydrogen fuel cells produce electricity through a chemical reaction between hydrogen and oxygen, with water vapor as the only by-product. Hydrogen-driven straddle carriers are locally emission-free. Large industries around the world are gearing up for hydrogen, and Konecranes is deeply involved as the most innovative OEM of container handling equipment.

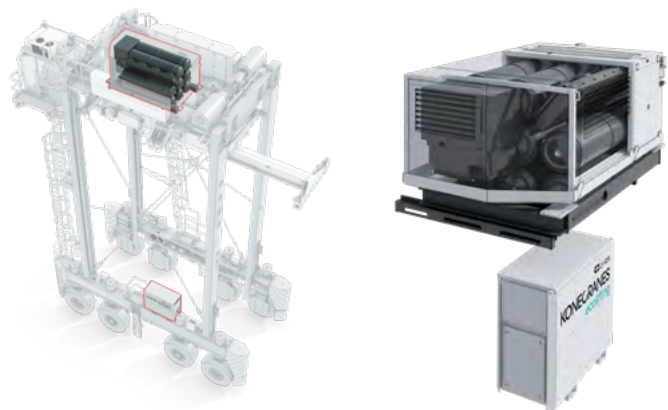

# Machinery platform

# Easy to access

The components of the machinery platform are arranged for easy access in order to make service and maintenance quick and convenient. Durable components are used to ensure long service intervals, significantly contributing to the high availability of Konecranes Noell Straddle Carriers. The hybrid, battery and hydrogen power options are arranged in a modular fashion. For the hybrid and battery versions, the batteries are located down on the sill beam.

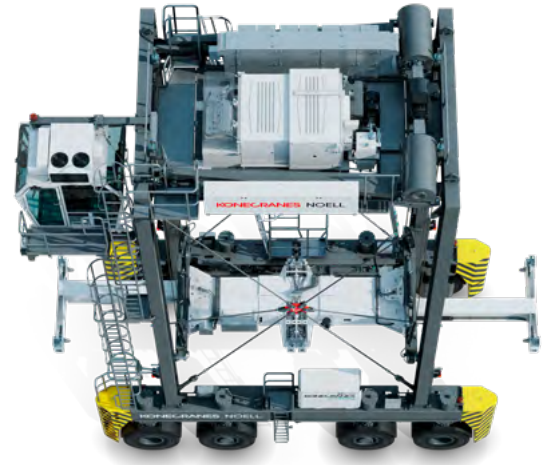

The hybrid version is shown here.

#### ELECTRICAL CABINETS

- Contain the electrical equipment
- All cabinets stainless steel, partially air-conditioned

#### HOISTING SYSTEM

- Maximum lifting capacity 60t
- Rope drums driven and synchronized by centrally positioned electric motor
- Maintenance-free, three-phase AC motor
- Simple, clearly arranged and protected rope guides
- Small number of rope pulleys for low rope wear
- Load detection at rope ends

#### DRIVE UNIT

- Hybrid shown here
- High-performance diesel-generator set
- Sliding cover for easy maintenance access to the engine and generator
- Different but modular configurations for battery, hydrogen versions

#### HYDRAULICS SYSTEM

- Supplies spreader, steering system and braking system
- Compact construction, physically separated from the power system (hybrid, battery, hydrogen)

#### WALKWAYS, LADDERS

Improved to enhance safety

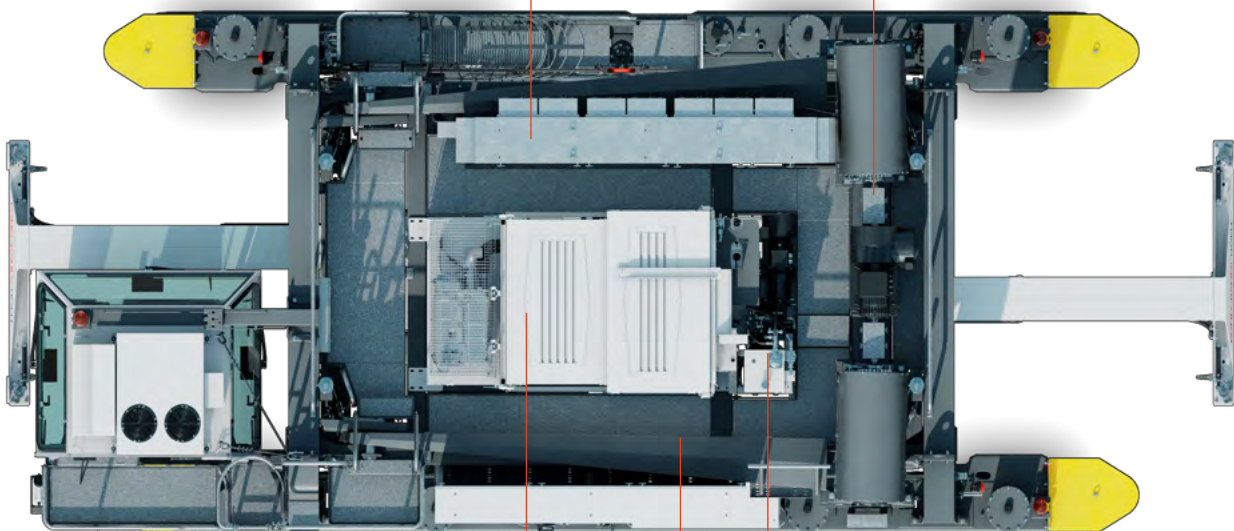

## Konecranes Noell Straddle Carriers

### Hoisting unit

		3-HIGH	4-HIGH
Nominal speeds	Lift/lower with empty / <40 t load	24.0 m/min	24.0 m/min
	Lift/lower with 40 t load	20.0 m/min	20.0 m/min
	Lift/lower with 50 t twin load*	16.0 m/min	16.0 m/min
Lifting and driving can be done simultaneously to increase the number of cycles. The electronic control prevents overloading of the diesel engine and ensures the distribution of load between the hoist unit and the chassis.			
Side shift/swing angle		+/-300 mm	+/-300 mm
		+/-6°	+/-6°

\* Data based on operation with twin spreader.

### Chassis

		3-HIGH	4-HIGH
Nominal speeds	With load	Approx. 30 km/h*	Approx. 24 km/h*
	Without load	Approx. 30 km/h*	Approx. 24 km/h*
Acceleration times 0–50 m	Without load	Approx. 12 s*	Approx. 12 s*
	With load	Approx. 15 s*	Approx. 15 s*
	Load and lift	Approx. 25 s*	Approx. 25 s*
Climbing ability	With / without load	Approx. 6 %	Approx. 6 %
Turning radius	Inside	Approx. 3.6 m	Approx. 3.6 m
	Outside (40' container)	Approx. 9.3 m	Approx. 9.3 m
Fuel tank	Total capacity of tank	750/1500 liters	750/1500 liters

\* With engine at normal operating temperature, head wind not exceeding 3 bft, and container in traveling position.

#### Remark:

Straddle carrier performance data relate to a nominal weight of 30.5 t which corresponds to the permissible gross weight of an ISO 40' container.

## Konecranes Noell Straddle Carriers

# Dimensions and weight

	3-HIGH	4-HIGH
Lifting height under twistlocks [H2]	9.1 m	12.0 m
Lowest position BE (below edge) spreader	0.3 m	0.3 m
Overall height (unloaded) [H1]	12.5 m	15.7 m
Overall length including ram buffer [L3]	10.3 m	10.3 m
Overall width (with front cab) [W2]	4.87 m	4.87 m
Clearance sill beam [W1]	3.47 m	3.47 m
Wheel base (inside wheels) [L1]	3.7 m	3.7 m
Wheel base (outside wheels) [L2]	7.7 m	7.7 m
Inside turning radius [R1]	3.6 m	3.6 m
Outside turning radius [R2]	9.3 m	9.3 m
Total weight, ready to operate*	69 t	72 t
<b>KONECRANES NOELL SPREADER</b>		
Spreader, single-lift [S1]	20 / 30 / 40 ft	20 / 30 / 40 ft
Spreader, twin-lift [S1]	20 / 30 / 40 / 2x20 ft	20 / 30 / 40 / 2x20 ft
Spreader, side shift [S2]	+/- 300 mm	+/- 300 mm
Spreader, swivel angle [S3]	+/- 6°	+/- 6°

\* Based on a hybrid straddle carrier with standard equipment, including single spreader

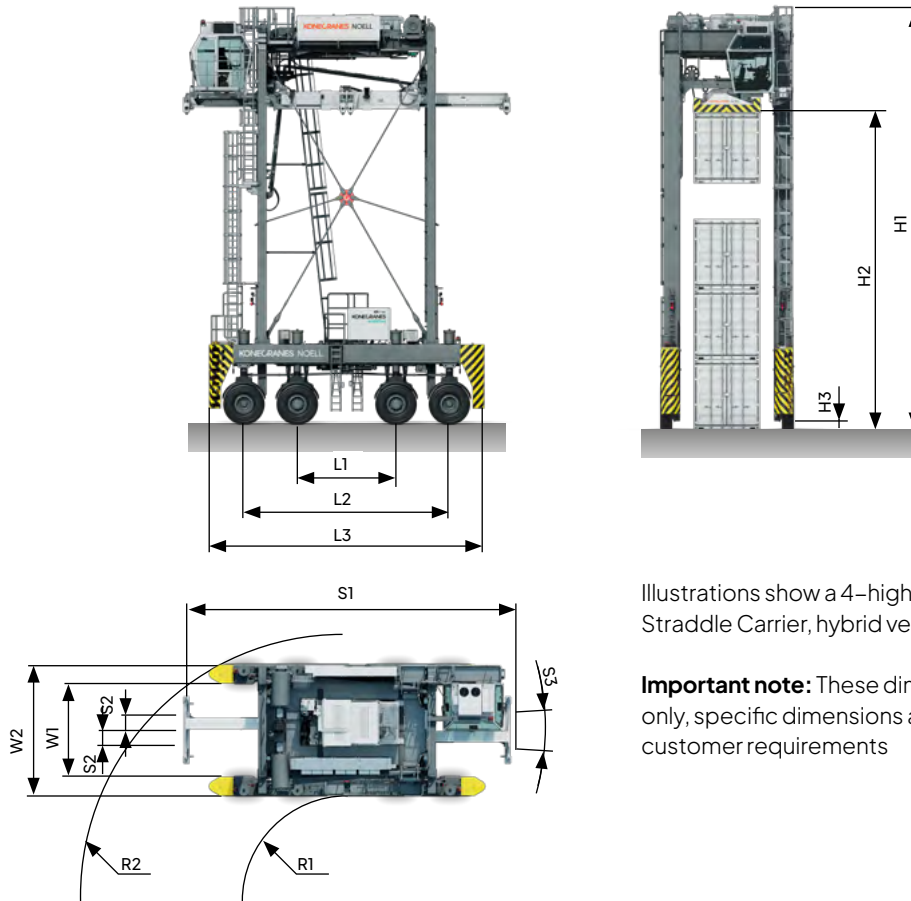

Illustrations show a 4-high Konecranes Noell Straddle Carrier, hybrid version

**Important note:** These dimensions are examples only, specific dimensions are as per project / customer requirements



Konecranes is a global leader in material handling solutions, serving a broad range of customers across multiple industries. We consistently set the industry benchmark, from everyday improvements to the breakthroughs at moments that matter most, because we know we can always find a safer, more productive and sustainable way. That's why, with around 16,600 professionals in over 50 countries, Konecranes is trusted every day to lift, handle and move what the world needs. In 2023, Group sales totalled EUR 4.0 billion. Konecranes shares are listed on Nasdaq Helsinki (symbol: KCR).

© 2024 Konecranes. All rights reserved. 'Konecranes' and  are either registered trademarks or trademarks of Konecranes.

This publication is for general informational purposes only. Konecranes reserves the right at any time, without notice, to alter or discontinue the products and/or specifications referenced herein. This publication creates no warranty on the part of Konecranes, express or implied, including but not limited to any implied warranty or merchantability or fitness for a particular purpose.

**KONECRANES** Moves what matters.