

How do

# crickets detect danger?

They have evolved small hairs that can detect the air current of a nearby frog opening its mouth.

**Safety. Evolved.**



## Safety-Assist Retrofits

Crane adaptations that detect danger and enable safer operations.

### Truck Lift Prevention

Sensor technology at ground-level detects any truck/trailer lift, and immediately halts the hoisting action for improved safety in manual handling mode. Works by detecting the trailer wheels.



Watch video at this link

### Adapt and thrive

Konecranes is the premier port services provider to brownfield terminal developments. Our range of retrofit products will enable your fleet to adapt to a fast-changing environment. Welcome to your evolution.

### Benefits

- Prevents the lifting of a trailer by automatically and rapidly stopping the lifting motion when a trailer lift is detected
- Stops hoist automatically and smoothly
- Monitors the movement of the truck's tyres, most other brands only follow the gap between the container and truck tyres
- Saves significant time in resolving trailer/truck lift incidents
- Works with terminal tractor, road trucks or AGVs.



**AB**  
Any Brand

This technology can be applied to all Konecranes RTGs as well as to other RTG brands. Installation of laser sensor and PLC connection may vary when implementing system to other RTG brands.

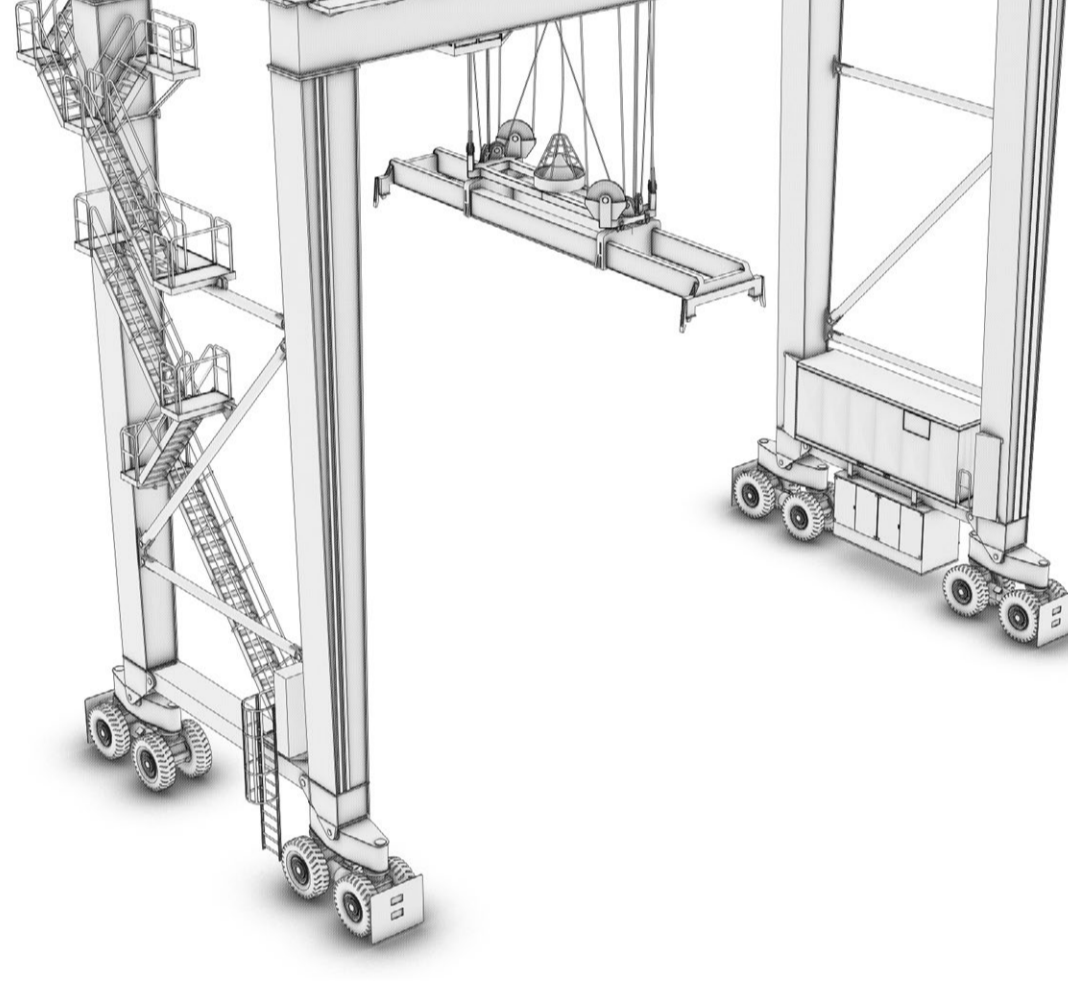

**RTG**  
Rubber-Tired Gantry Crane



### How it works

- A laser, mounted under the sill beam, is activated when the trolley is above the trucking lane
- The spreader is lowered onto the container and the twist locks are moved to the closed position
- The sensor remains active during the first 2 meters of hoisting.

### What you need to know

- If there is no auxiliary generator or other structure a more comprehensive bracket with long arm is required
- Turn-key project delivery with all required hardware and software plus training
- Site works and commissioning: 2 days per crane
- Customer needs to ensure prompt availability of cranes to ensure the above timelines
- Customer needs to ensure prompt availability and safe work location to ensure the timelines.

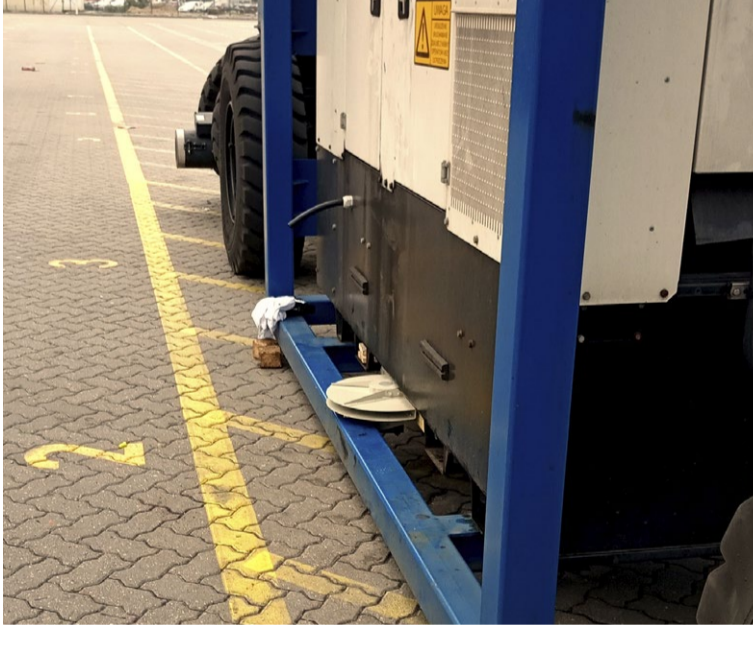

### Selected References



| YEAR    | CUSTOMER/LOCATION | QUANTITY |
|---------|-------------------|----------|
| 2019/20 | SCPA / Charleston | 69       |
| 2019/20 | GPA / Savannah    | 32       |
| 2019/20 | LKP / Koper       | 7        |
| 2019    | DPW / Djazair     | 5        |
| 2015    | DPW / Yarimca     | 24       |

### Ports. Evolved.



Konecranes is a global leader in material handling solutions, serving a broad range of customers across multiple industries. We consistently set the industry benchmark, from everyday improvements to the breakthroughs at moments that matter most, because we know we can always find a safer, more productive and sustainable way. That's why, with around 16,600 professionals in over 50 countries, Konecranes is trusted every day to lift, handle and move what the world needs. In 2023, Group sales totalled EUR 4.0 billion. Konecranes shares are listed on Nasdaq Helsinki (symbol: KCR).

© 2024 Konecranes. All rights reserved. 'Konecranes', 'Moves what matters' and 'C' are either registered trademarks or trademarks of Konecranes. This publication is for general informational purposes only. Konecranes reserves the right at any time, without notice, to alter or discontinue the products and/or specifications referenced herein. This publication creates no warranty on the part of Konecranes, express or implied, including but not limited to any implied warranty or merchantability or fitness for a particular purpose.