

How do

Indigo Buntings locate the same acre of land every summer?

They calculate their position using the stars.



Positioning. Evolved.

Auto-Path Optimizing

System calculates optimum trolley-hoist trajectory for improved fuel efficiency, cycle times and safety.



Watch video at this link

Adapt and thrive

Konecranes is the premier port services provider to brownfield terminal developments. Our range of retrofit products will enable your fleet to adapt to a fast-changing environment. Welcome to your evolution.

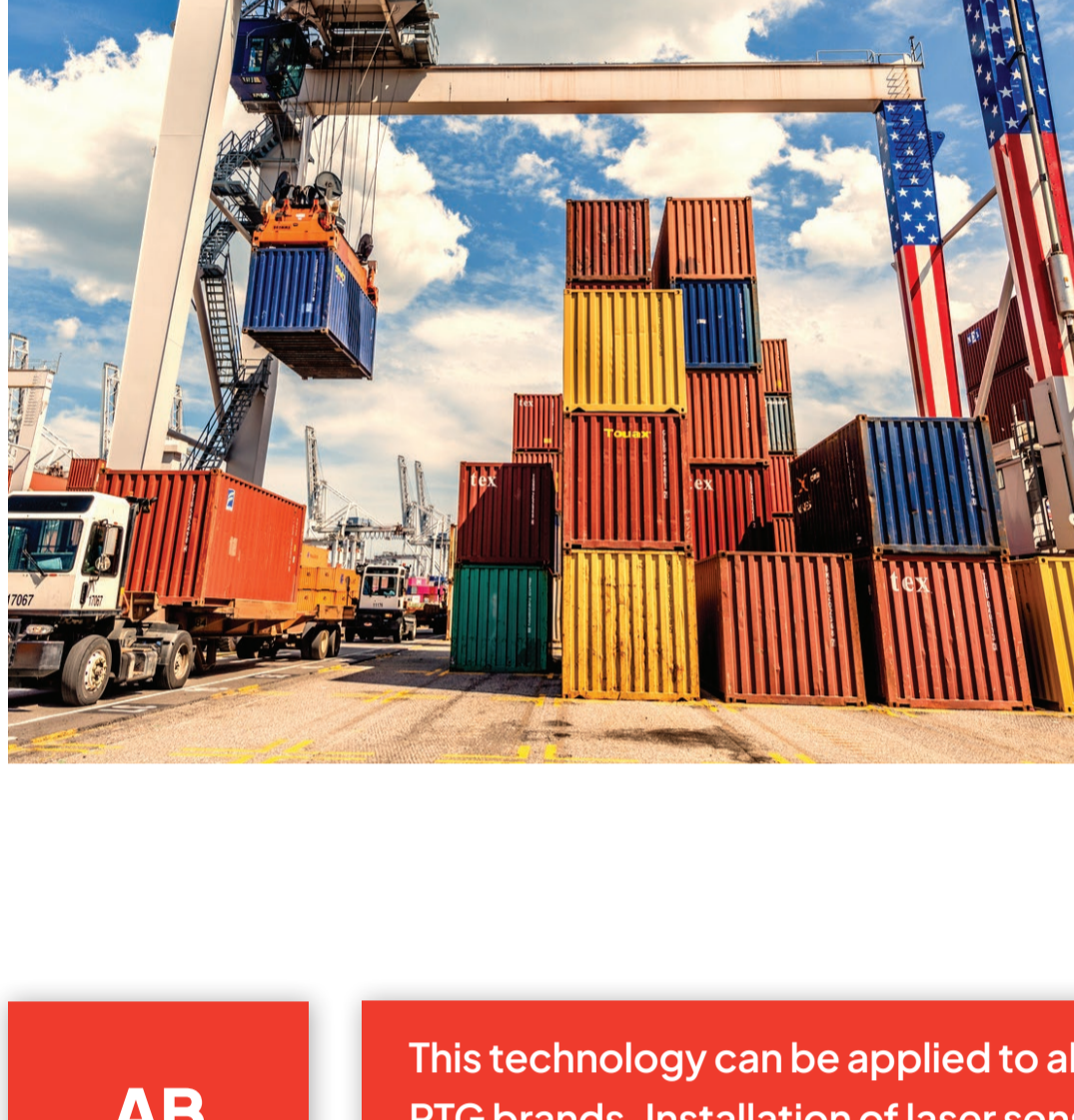

Benefits

- Energy consumption can be reduced
- Cycle times are improved
- System prevents collision with stacks and guides container along the shortest route
- Semi-automated: all stacking operations, i.e. picking and placing containers, is still handled manually.

AB

Any Brand

This technology can be applied to all Konecranes RTGs as well as to other RTG brands. Installation of laser sensor and PLC connection may vary when implementing system to other RTG brands. Auto-TOS and Stack-Collision retrofits are a prerequisite.

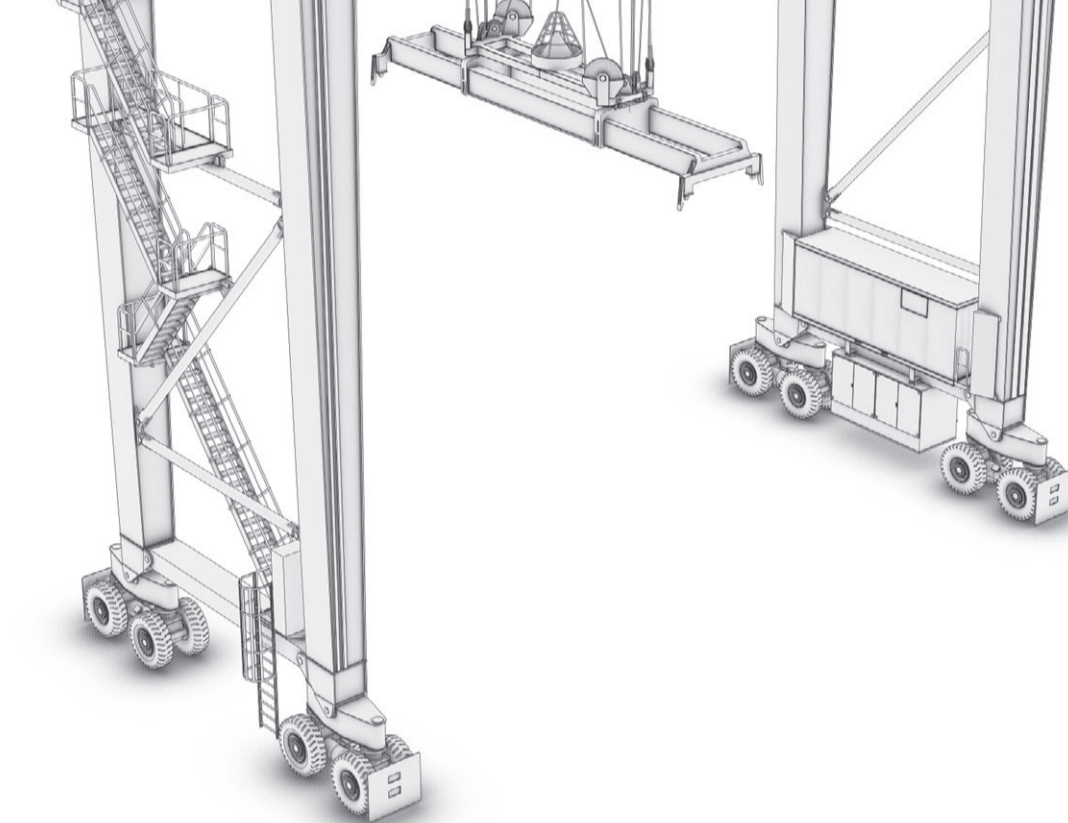

RTG

Rubber-Tired Gantry Crane

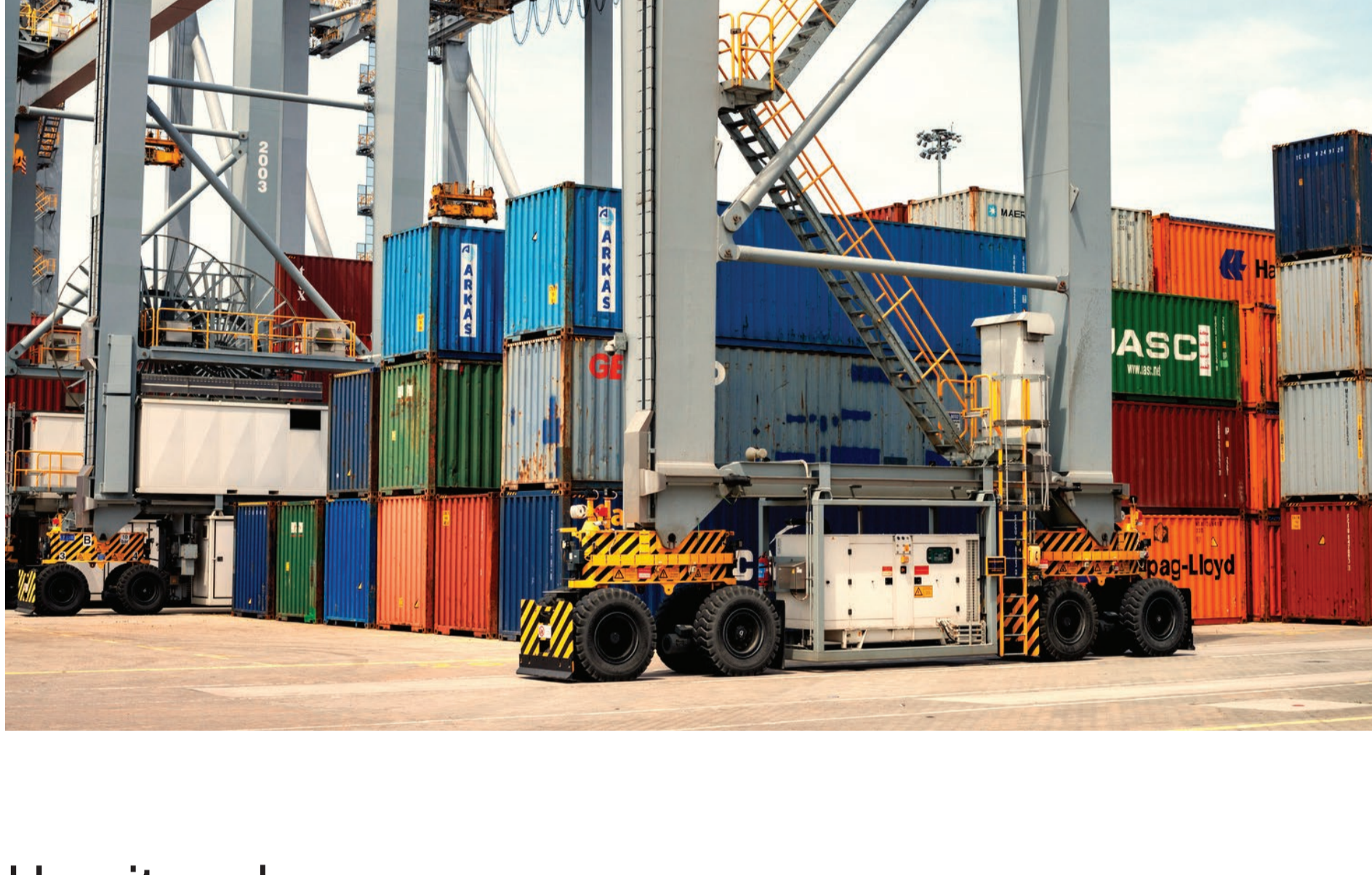

How it works

- Technology is activated by pressing a foot pedal
- The foot pedal works in a hold-to-run principle
- The Industrial PC receives the data from the lasers and constantly calculates the stack profile
- It then continuously provides the PLC with distances to the containers in the trolley's path
- Above 18 meters with a container and above 15 meters with an empty spreader, the trolley movement is always free.

What you need to know

- Auto-TOS and Stack-Collision retrofits are a prerequisite.
- Auto-Path is a mandatory function for further automation
- Site works and commissioning: 2 days per crane
- Customer needs to provide a safe location where installation and commissioning can be completed.



Selected References



YEAR	CUSTOMER/LOCATION	QUANTITY
2021	Yilport / Leixhoes	6
2020	DPW / Yarimca	6
2020	Yilport / Gävle	6
2020	Yilport / Liscont	6
2019	MFT / Malta	15
2019	PTP / Johor	12
2018	PMT / Kuala Tanjung	8

Ports. Evolved.



Konecranes is a global leader in material handling solutions, serving a broad range of customers across multiple industries. We consistently set the industry benchmark, from everyday improvements to the breakthroughs at moments that matter most, because we know we can always find a safer, more productive and sustainable way. That's why, with around 16,600 professionals in over 50 countries, Konecranes is trusted every day to lift, handle and move what the world needs. In 2023, Group sales totalled EUR 4.0 billion. Konecranes shares are listed on Nasdaq Helsinki (symbol: KCR).

© 2024 Konecranes. All rights reserved. 'Konecranes', 'Moves what matters' and are either registered trademarks or trademarks of Konecranes.

This publication is for general informational purposes only. Konecranes reserves the right at any time, without notice, to alter or discontinue the products and/or specifications referenced herein. This publication creates no warranty on the part of Konecranes, express or implied, including but not limited to any implied warranty or merchantability or fitness for a particular purpose.