

# How can 30% of a jelly fish's propulsion require zero energy?

[contact us](#)

An evolved dual vortex system, that creates thrust even when the muscles are inactive.

**Power. Evolved.**



## Ecolifting Retrofits

Simple electrical conversions that make crane movement safer, quieter and more efficient.

## RTG Cable Reel

This fully electric conversion enables less fuel consumption, less maintenance, lower noise levels and fewer carbon emissions.

## Adapt and thrive

Konecranes is the premier port services provider to brownfield terminal developments. Our range of retrofit products will enable your fleet to adapt to a fast-changing environment. Welcome to your evolution.

## Benefits

- Converts crane to 100% electric supply.
- Eliminates the need for refuelling and maintenance of diesel engines.
- Reduced annual running costs.
- Fewer emissions and less noise.

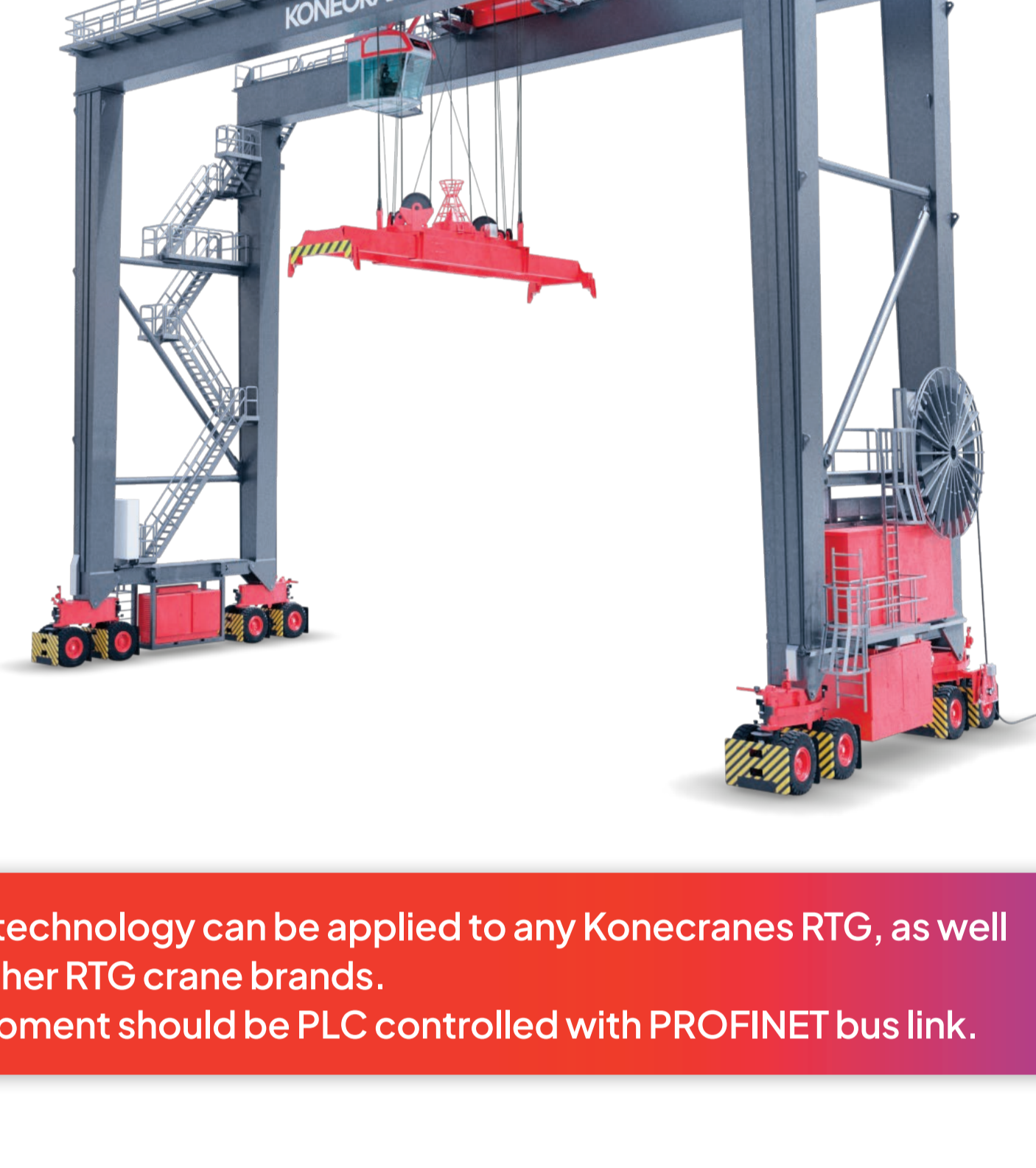

**AB**  
Any Brand

This technology can be applied to any Konecranes RTG, as well as other RTG crane brands. Equipment should be PLC controlled with PROFINET bus link.

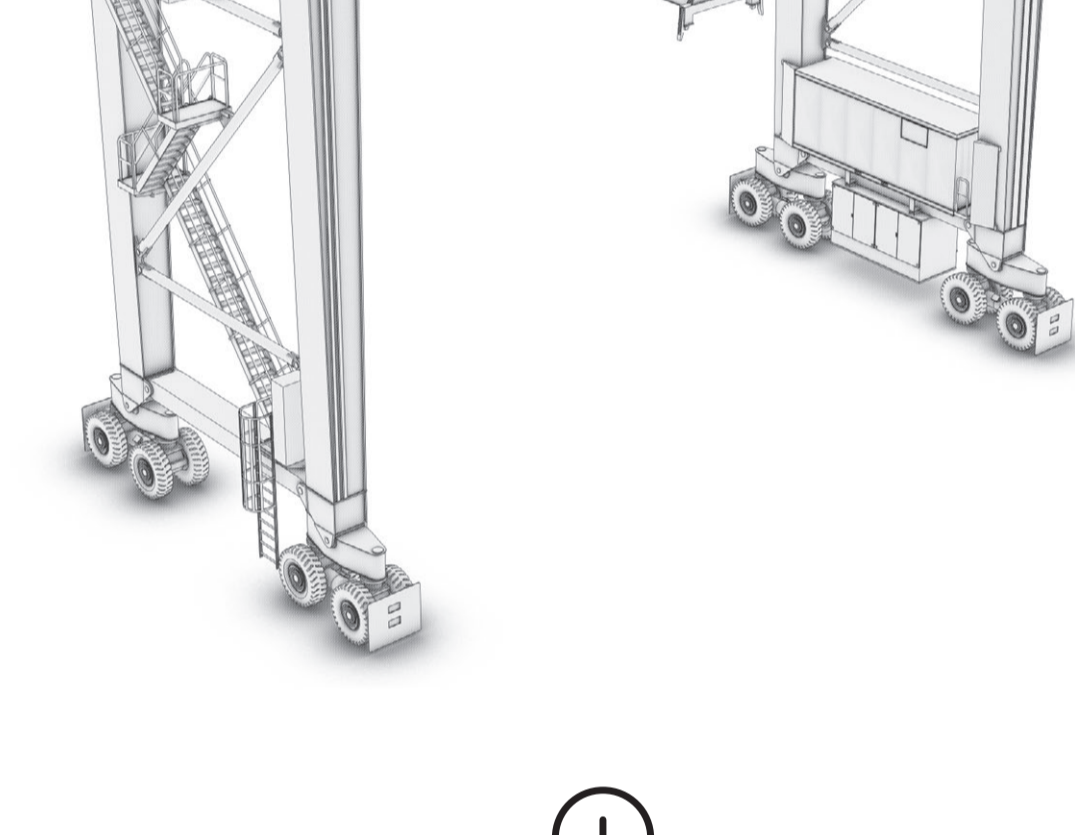

**RTG**  
Rubber-Tired Gantry Crane

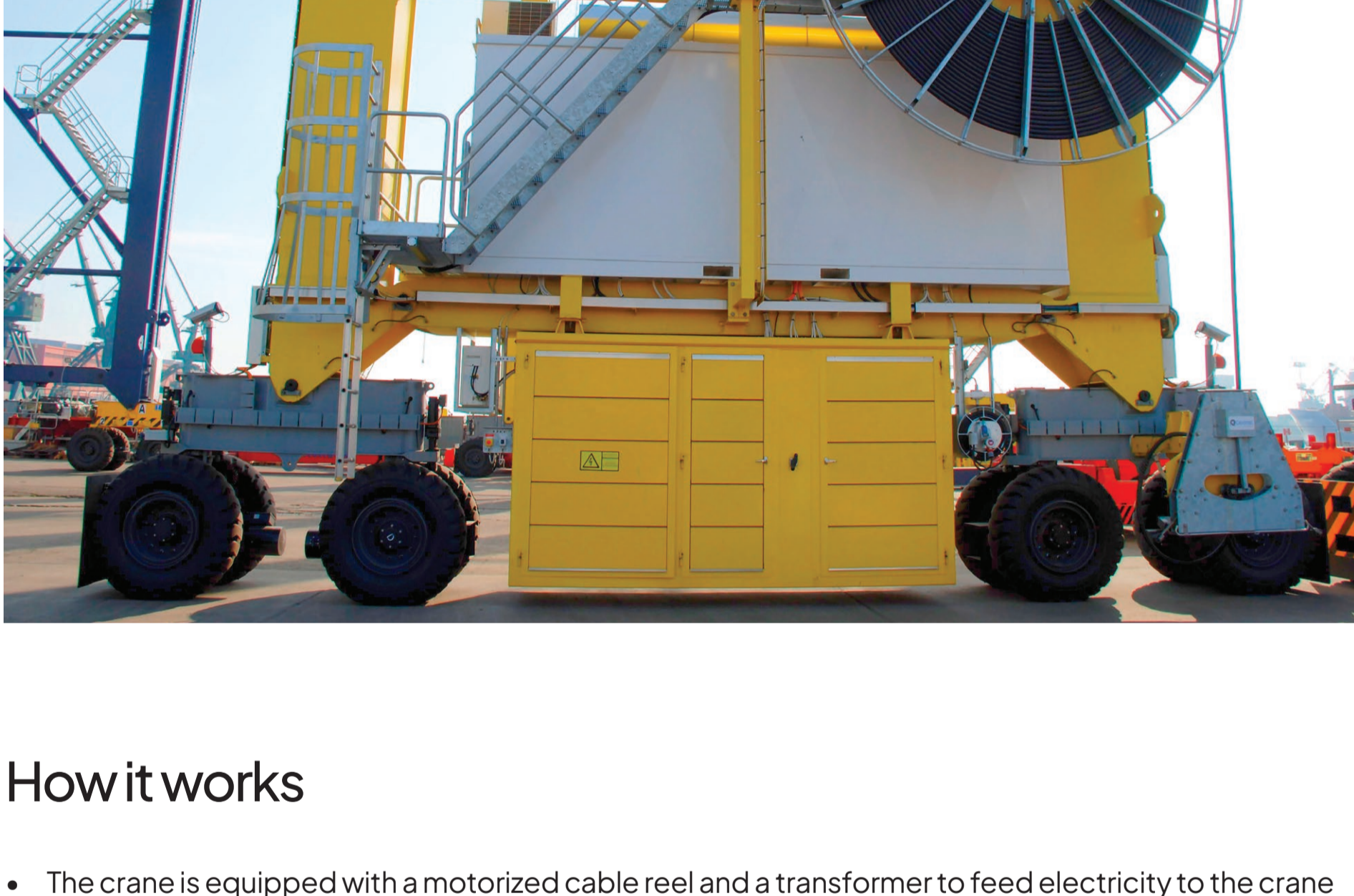

## How it works

- The crane is equipped with a motorized cable reel and a transformer to feed electricity to the crane from the port mains.
- The power is fed to the crane through a flexible cable that coils automatically on/off a reel body on the crane while travelling.
- Reeling cable is stored alongside container stacking area and ends in either an end or centre feeding point pit station with appropriate plug/socket connection to the port's mains.
- It can be supplied in either Medium Voltage power or Low Voltage power.

## What you need to know

- Auto-Steering feature is mandatory for RTGs - to operate on virtual track alongside reeling cable tray on ground level.
- Customer is responsible for all site related civil works, infrastructure works and site related equipment, such as yard power supply and distribution system.
- Customer is required to provide either LV (1000V) or HV (up to max 12kV) supplying voltage on a yard junction box with plug connection.
- Konecranes will assist in providing the necessary information for our customers to complete these tasks.



## Selected References



YEAR	CUSTOMER/LOCATION	QUANTITY
2022	PD Ports/ Teesport	4
2021	HSL/ Glasgow	1
2020	CTSP / St Petersburg	2
2020	DPW / Yarimca	6
2020	MSC / Lausado	3
2020	GT / Cai Mep	18

## Ports. Evolved.



Konecranes is a global leader in material handling solutions, serving a broad range of customers across multiple industries. We consistently set the industry benchmark, from everyday improvements to the breakthroughs at moments that matter most, because we know we can always find a safer, more productive and sustainable way. That's why, with around 16,600 professionals in over 50 countries, Konecranes is trusted every day to lift, handle and move what the world needs. In 2023, Group sales totalled EUR 4.0 billion. Konecranes shares are listed on Nasdaq Helsinki (symbol: KCR).

© 2024 Konecranes. All rights reserved. 'Konecranes', 'Moves what matters' and are either registered trademarks or trademarks of Konecranes.

This publication is for general informational purposes only. Konecranes reserves the right at any time, without notice, to alter or discontinue the products and/or specifications referenced herein. This publication creates no warranty on the part of Konecranes, express or implied, including but not limited to any implied warranty of merchantability or fitness for a particular purpose.