

How can 30% of a jelly fish's propulsion require zero energy?

[contact us](#)

An evolved dual vortex system, that creates thrust even when the muscles are inactive.

Power. Evolved.



Simple electrical conversions that make crane movement safer, quieter and more efficient.

Hybrid Power Pack

The Hybrid Power Pack turns a diesel RTG into a diesel-electric hybrid RTG without compromising the capacity. With the hybrid power pack, you can reduce operational costs dramatically.

Adapt and thrive

Konecranes is the premier port services provider to brownfield terminal developments. Our range of retrofit products will enable your fleet to adapt to a fast-changing environment. Welcome to your evolution.

Benefits

- Maximize crane uptime
- Drastically reduce maintenance and running costs
- Significantly lower fuel consumption
- Increased eco-efficiency with fewer emissions and significantly lower noise levels
- Reduce time spent refueling and maintaining diesel engines

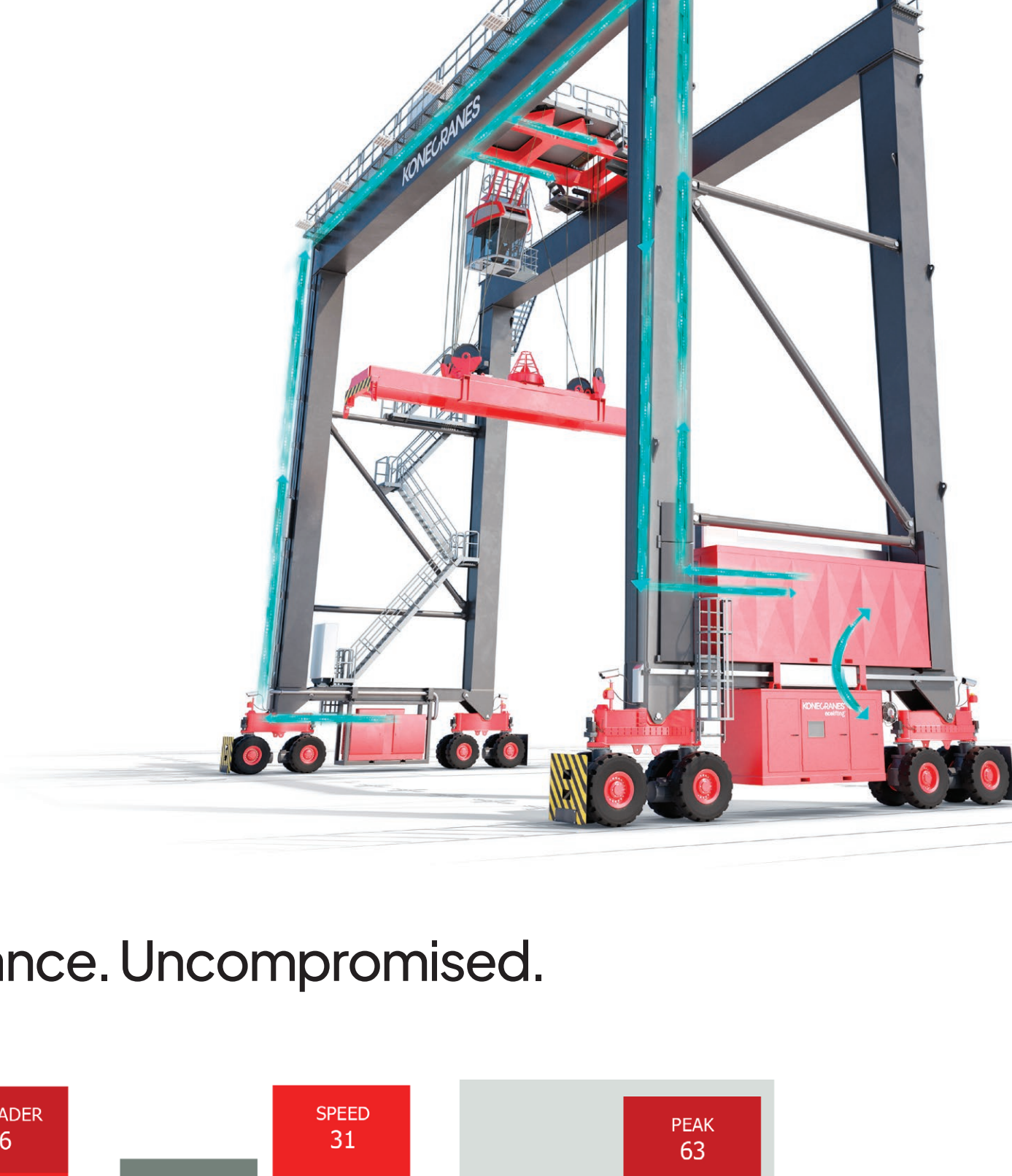

Performance. Uncompromised.

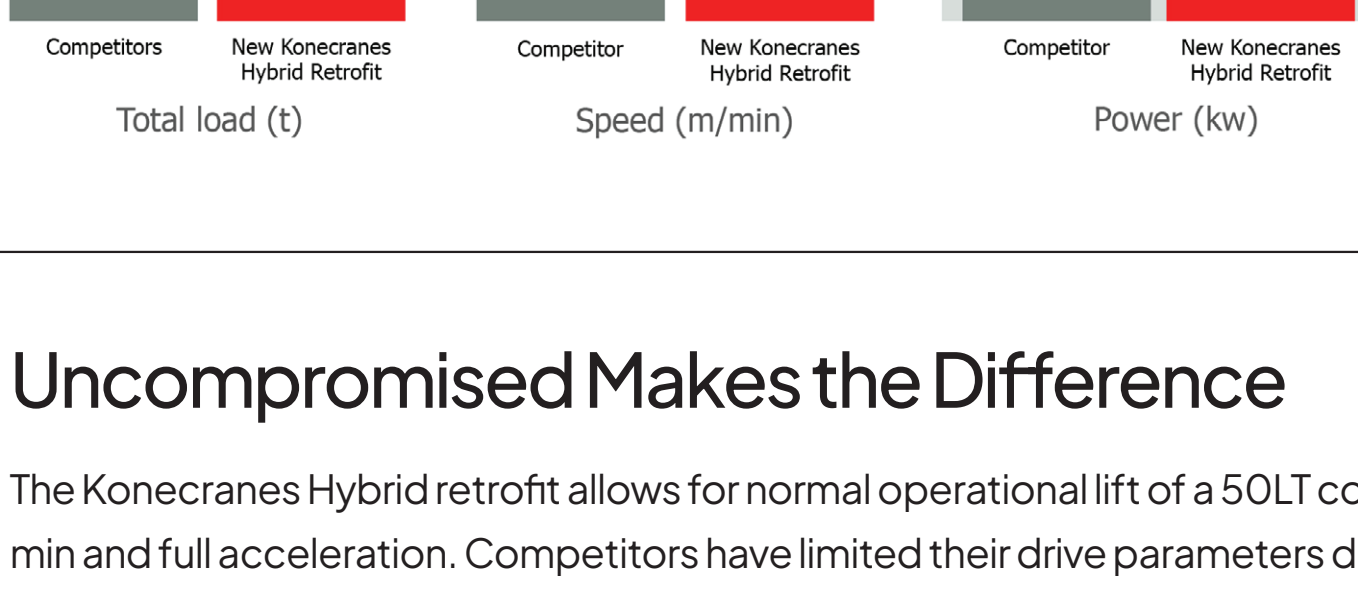

Uncompromised Makes the Difference

The Konecranes Hybrid retrofit allows for normal operational lift of a 50LT container, with a speed of 31m/min and full acceleration. Competitors have limited their drive parameters due to limited power capacity.

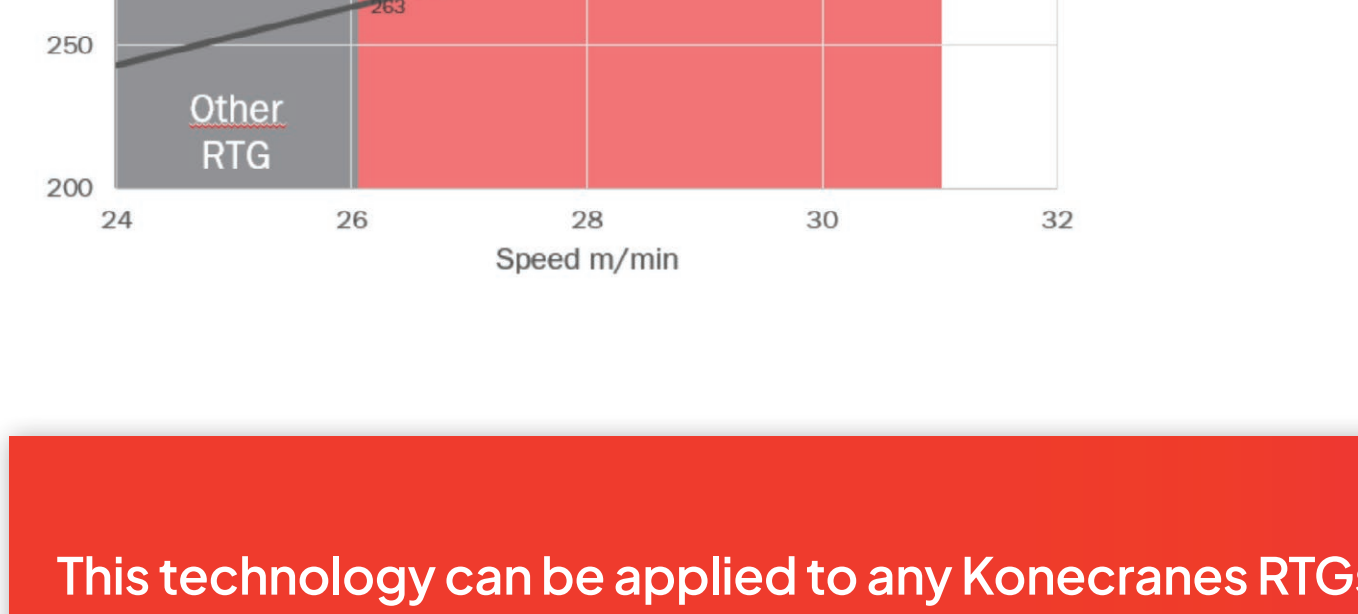

This technology can be applied to any Konecranes RTGs.

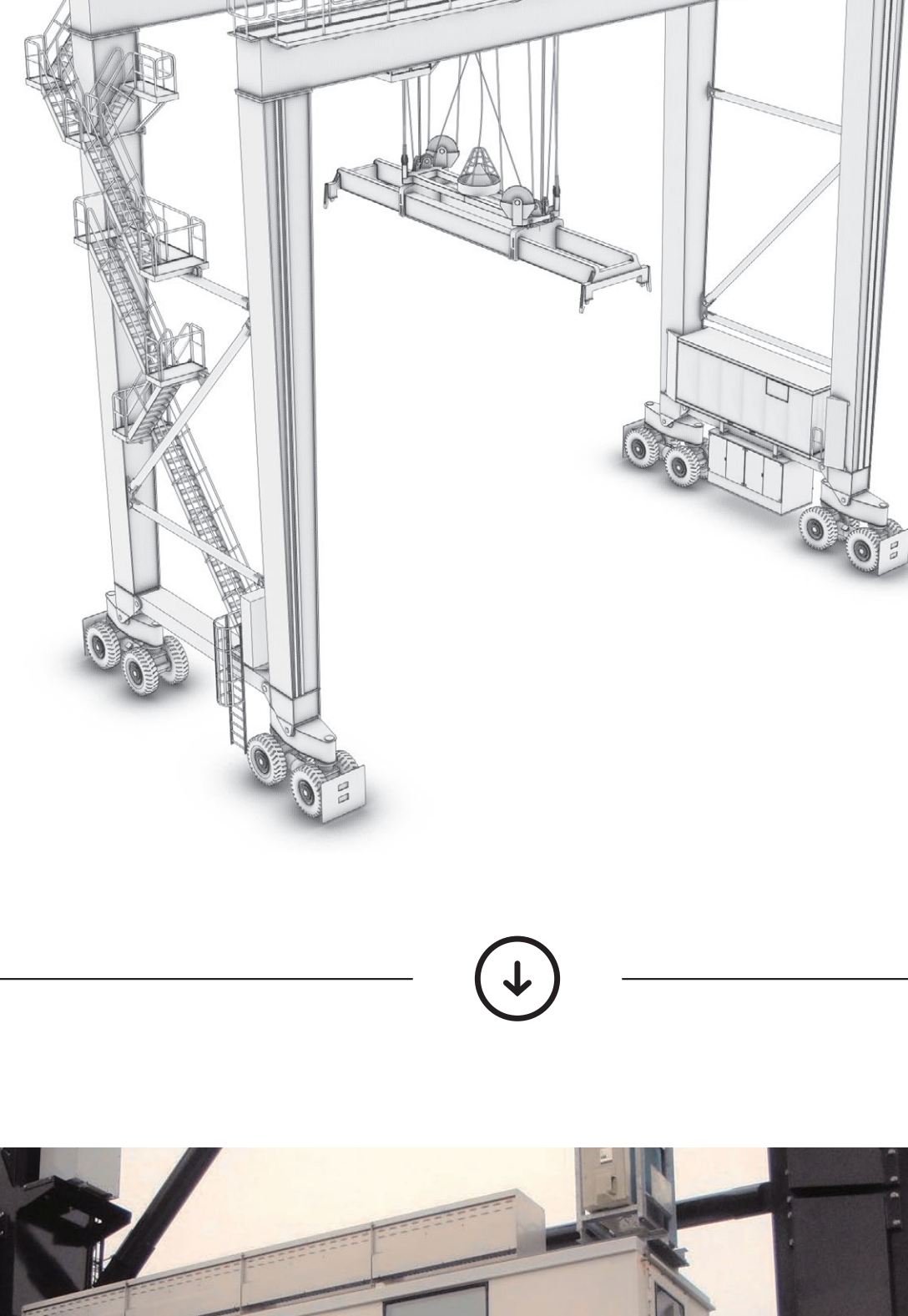

RTG
Rubber-Tired Gantry Crane



How it works

- The crane is operated with electrical power from the battery and diesel generator.
- In normal use the operations use only battery charged energy and at peak power (over 40LT) diesel and battery are operating parallel.
- The energy from braking is recharged to the battery.

What you need to know

- Small new diesel genset for battery charging purposes installed on the access of RTG, suitable for emergency use of all motions with reduced speeds
- Designed for high utilization (13 mph, 20 h/d, 350 d/y= 91 000 moves / year)
- Batteries in constant control, charge monitoring with graphical interface, liquid cooling for module temperature control, active balancing function, 300kW in both directions. DC-DC converter for controlling power flow between battery pack and the common-DC bus network.
- Complete integration of Konecranes systems
 - to Konecranes PLC crane control system
 - to Konecranes CMS monitoring system
 - to Konecranes Truconnect remote service system
 - done by Konecranes

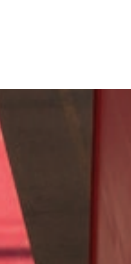

Ports. Evolved.

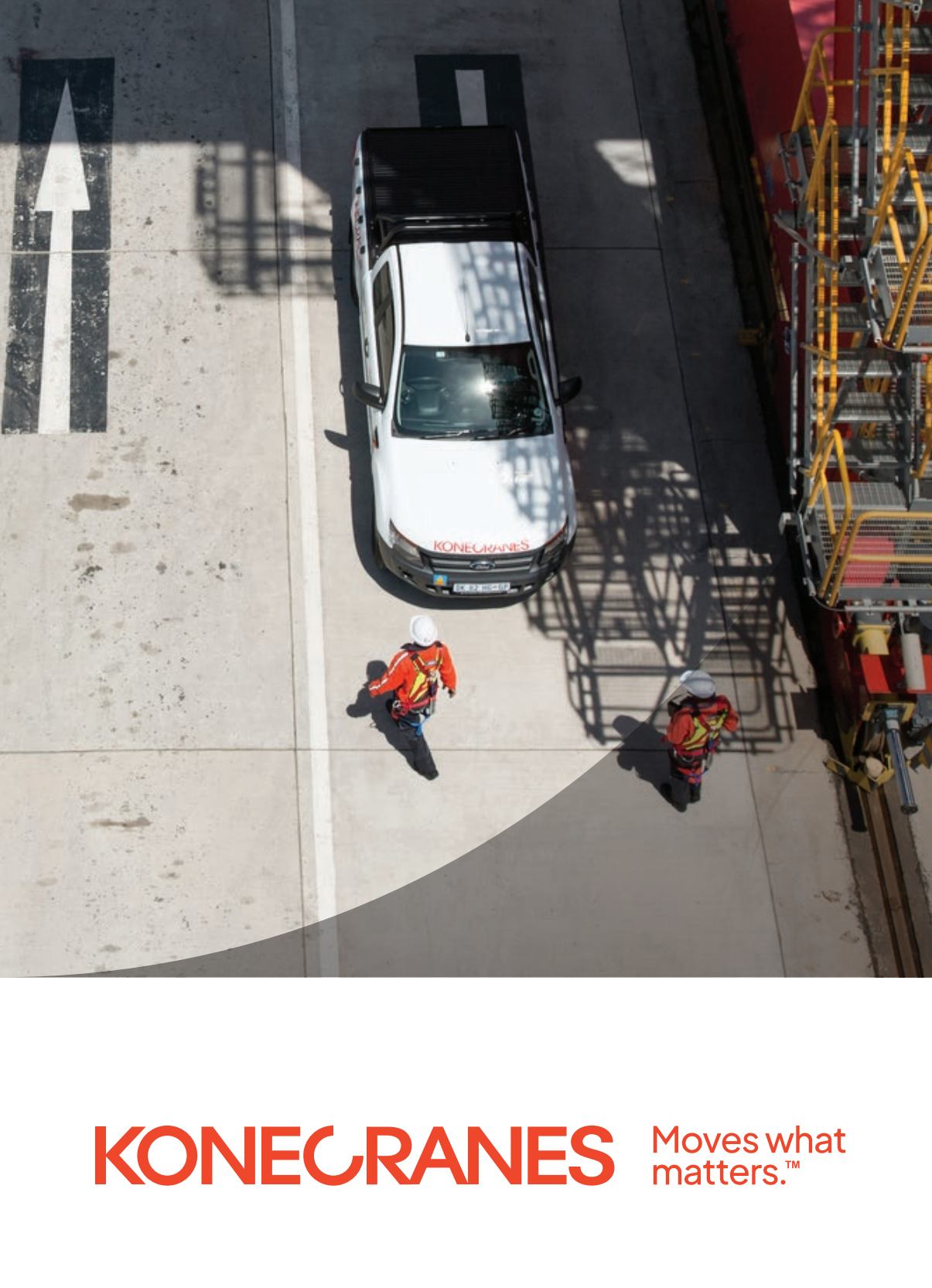

Konecranes is a global leader in material handling solutions, serving a broad range of customers across multiple industries. We consistently set the industry benchmark, from everyday improvements to the breakthroughs at moments that matter most, because we know we can always find a safer, more productive and sustainable way. That's why, with around 16,600 professionals in over 50 countries, Konecranes is trusted every day to lift, handle and move what the world needs. In 2023, Group sales totalled EUR 4.0 billion. Konecranes shares are listed on Nasdaq Helsinki (symbol: KCR).

© 2024 Konecranes. All rights reserved. "Konecranes", "Moves what matters" and are either registered trademarks or trademarks of Konecranes.
This publication is for general informational purposes only. Konecranes reserves the right at any time, without notice, to alter or discontinue the products and/or specifications referenced herein. This publication creates no warranty on the part of Konecranes, express or implied, including but not limited to any implied warranty or merchantability or fitness for a particular purpose.