

How can 30% of a jelly fish's propulsion require zero energy?

[contact us](#)

An evolved dual vortex system, that creates thrust even when the muscles are inactive.

Power. Evolved.



Simple electrical conversions that make crane movement safer, quieter and more efficient.

Busbar

A conductor rail is installed to the steel structure along a container stacking area, providing consistent electric power that is cleaner and cheaper than diesel.

Adapt and thrive

Konecranes is the premier port services provider to brownfield terminal developments. Our range of retrofit products will enable your fleet to adapt to a fast-changing environment. Welcome to your evolution.

Benefits

- Eliminates diesel fuel consumption completely
- Eliminates time spent refuelling
- Typically 25–30% of total downtime is related to diesel engine maintenance, electrification saves those costs
- Optional: Drive In/Drive Out procedure can be automated with Konecranes proprietary "one button" feature
- Full diesel-genset remains available as back-up and auxiliary.



Fuel Savings

Assumed parameters
 average load: 30t cycle: 12 boxes/h operational hours: 3600/year
 fuel cost: 95ct/l electrical energy cost: 11ct/kWh

	DIESEL ENGINE POWER WITH FIXED SPEED MODE	BUSBAR POWER WITHOUT NETWORK BRAKING	BUSBAR POWER INCL. NETWORK BRAKING
needed energy /h	14,8 l/h	59.0 kWh	27.5 kWh
fuel cost /h	13.50 €/h	6,50 €/h	3,00 €/h
running cost /year	47.790,-EUR	23.376,-EUR	10.749,-EUR
cost difference to diesel /year		-24.415,-EUR	-37.042,-EUR
up to ...% saving /year		50%	75%

AB Any Brand This technology can be applied to all Konecranes RTGs as well as any other crane brand. RTGs should be PLC controlled with PROFINET bus link.

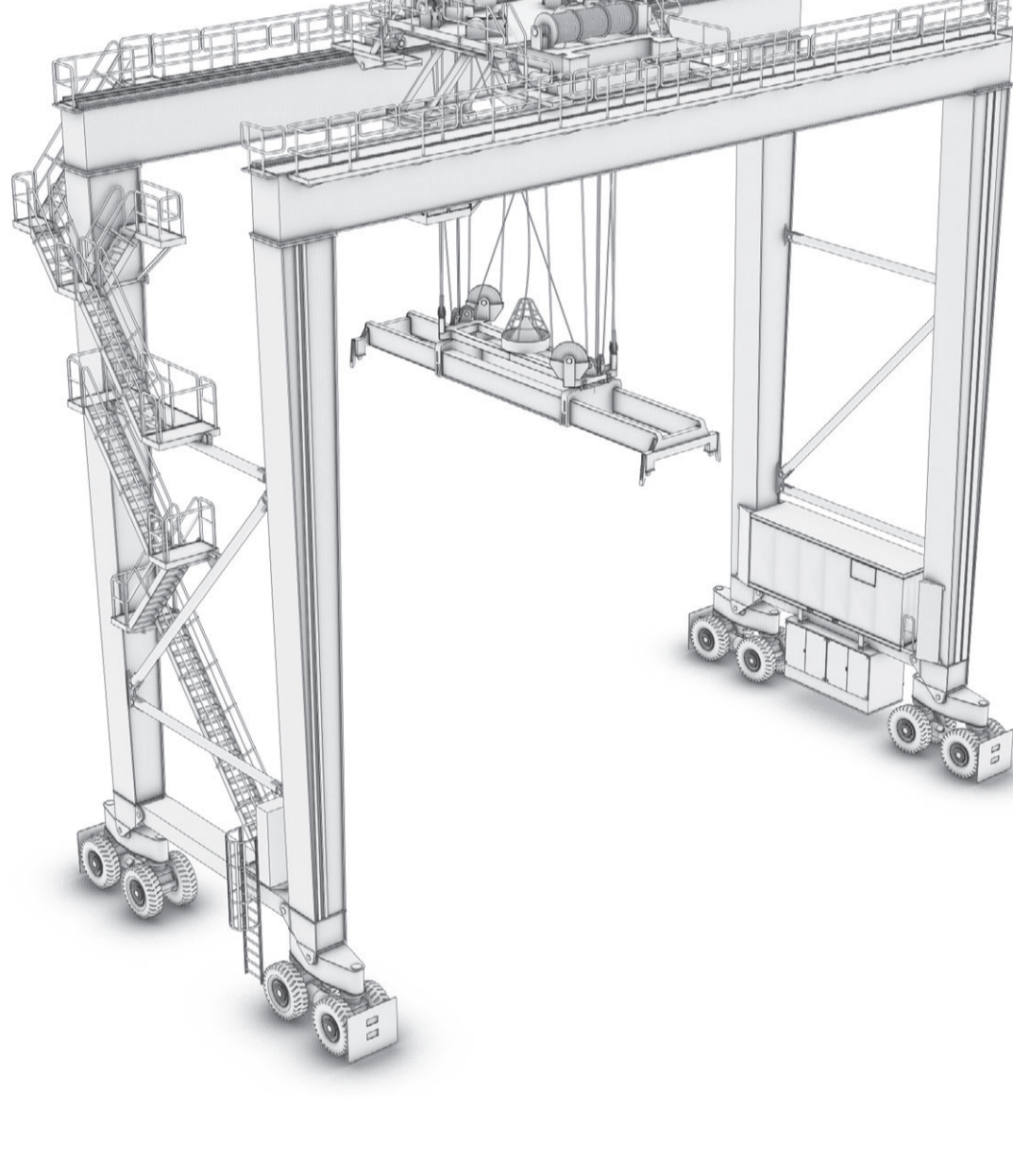

RTG
Rubber-Tired Gantry Crane



How it works

- The new electrical power supply source is fed by conductor rail system, consistently in-touch with the RTG
- The existing diesel genset remains on the RTG for container stack changes
- A special telescopic arm connects the RTG with the conductor rail and mains power
- Coupling and uncoupling sequences are activated by PLC control.

What you need to know

- Auto-Steering smart feature is mandatory to operate RTG on virtual track alongside busbar rail
- Customer is required to provide supplying conductor rail voltage in same level as RTG's nominal board voltage
- Standard values are 400V up to max 690V. If there a need to run different types of RTGs on one common conductor rail, the RTGs need to match frequency and voltage of grid power
- Customer is responsible for:
 - all site related civil works, infrastructure works and site related equipment, such as yard busbar system, pillar boxes, transformers, breakers, etc.



Selected References



YEAR	CUSTOMER/LOCATION	QUANTITY
2020/21	Gulfstream /Wilmington	9
2019	LCT /Lomé	11
2017/19	MSC /Valencia	9
2015/16	POE /Frt. Lauderdale	4

Ports. Evolved.



Konecranes is a global leader in material handling solutions, serving a broad range of customers across multiple industries. We consistently set the industry benchmark, from everyday improvements to the breakthroughs at moments that matter most, because we know we can always find a safer, more productive and sustainable way. That's why, with around 16,600 professionals in over 50 countries, Konecranes is trusted every day to lift, handle and move what the world needs. In 2023, Group sales totalled EUR 4.0 billion. Konecranes shares are listed on Nasdaq Helsinki (symbol: KCR).

© 2024 Konecranes. All rights reserved. "Konecranes", "Moves what matters" and are either registered trademarks or trademarks of Konecranes.
 This publication is for general informational purposes only. Konecranes reserves the right at any time, without notice, to alter or discontinue the products and/or specifications referenced herein. This publication creates no warranty on the part of Konecranes, express or implied, including but not limited to any implied warranty or merchantability or fitness for a particular purpose.