

SMART FEATURE RETROFITS

Auto-TOS Reporting Retrofit

Now every crane can count its moves, map the position of every load and interface directly with the TOS.

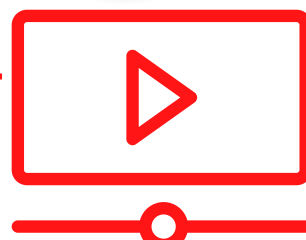
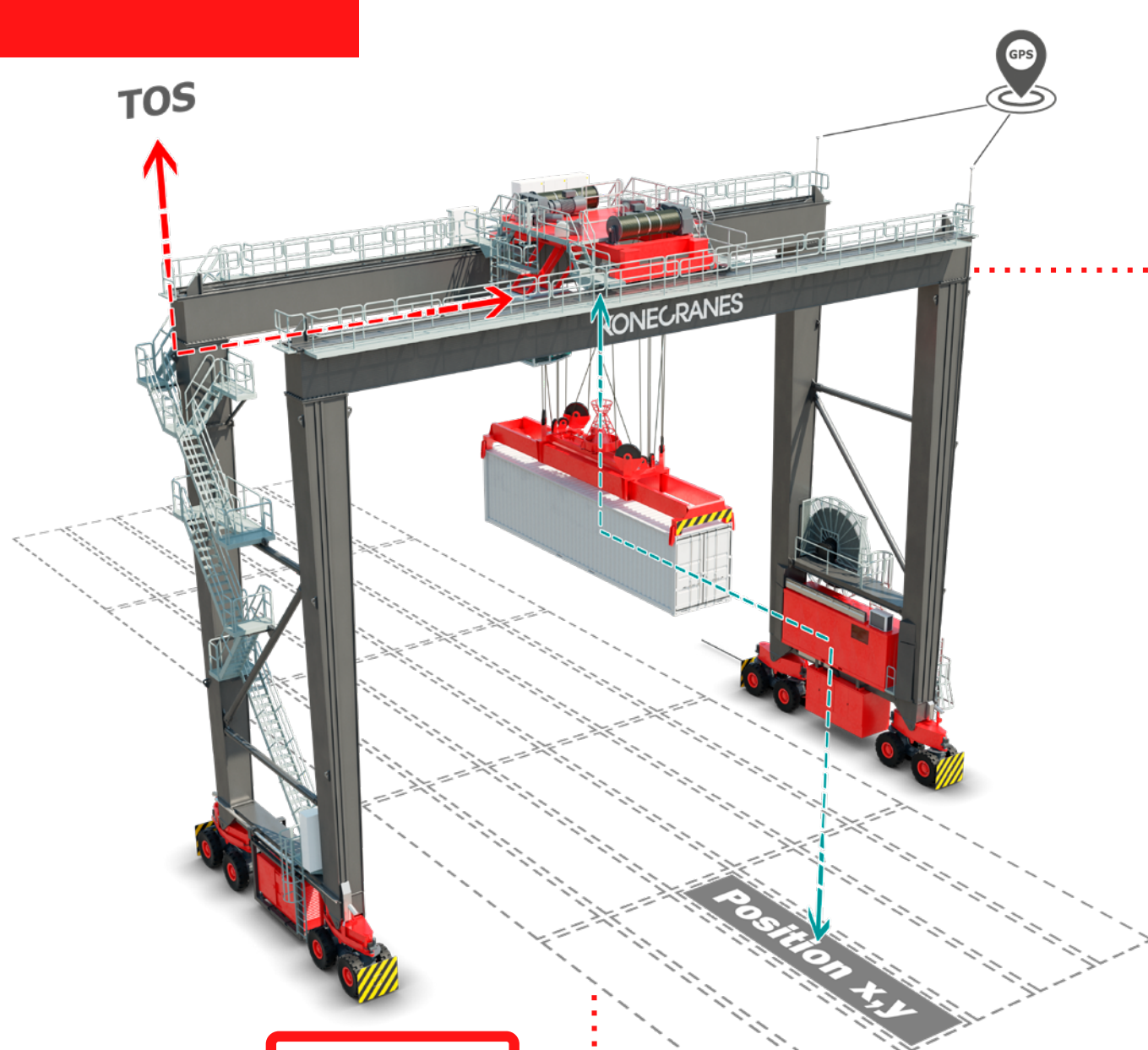

Watch video at this link

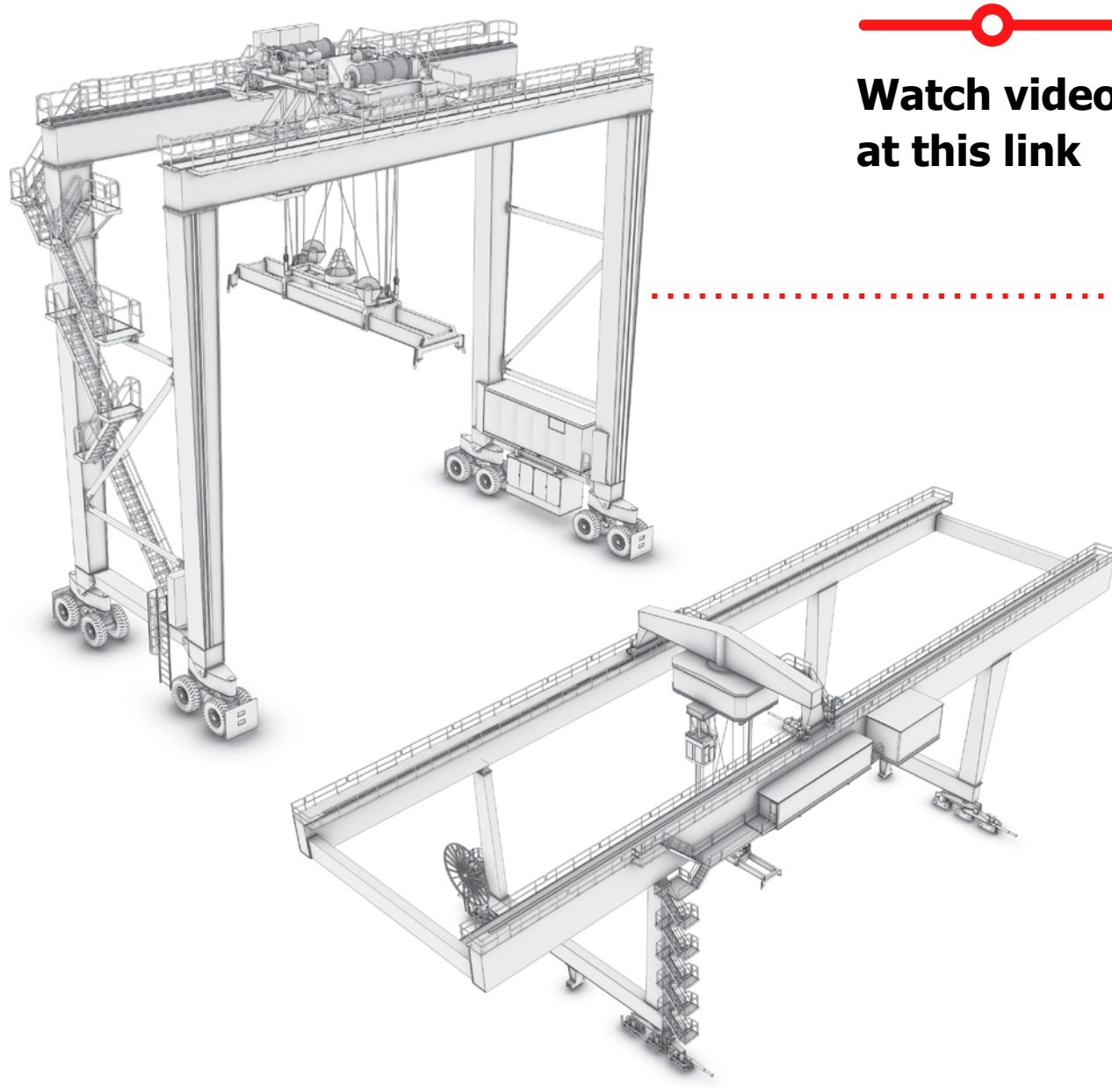

EQUIPMENT

This technology can be applied to all Konecranes RTGs and RMGs as well as to **other crane brands**.

- AB**
Any Brand
- RTG**
Rubber-Tyred Gantry
- RMG**
Rail-Mounted Gantry



BENEFITS

- Keeps TOS data up-to-date in real-time
- Process is invisible to the operator
- 100% accurate yard inventory
- Eliminates misplacing containers in the yard
- Tracks moves regardless of whether they follow TOS instructions, are diverted from them or are completely unauthorized
- Proprietary DGPS algorithms calculate centimetre level accurate GPS positions.

HOW IT WORKS

- Systems uses a combination of DGPS, radio radar and distance sensors
- Translates the crane's position into the logical container positions used by the TOS
- The Auto-TOS reporting system interfaces with the crane's control system to detect container pick-up and placement actions, then uses the crane's GPS position to calculate container positions.

WHAT YOU NEED TO KNOW

- Auto-TOS reporting is mandatory function for further automation
- Auto-steering or position detection system are prerequisites for Auto-TOS reporting
- Site works and commissioning 1-2 days per crane
- Customer needs:
 - To apply for necessary radio frequency license that the system needs for the base station communication
 - To name a location for the base station and install the cubicle, antenna and wiring. Konecranes builds the antenna connection
 - If WLAN is used, to provide a functional WLAN network with strong coverage in the whole area where the RTGs operate (optional)
- Konecranes will assist in providing the necessary information for our customers to complete these tasks.

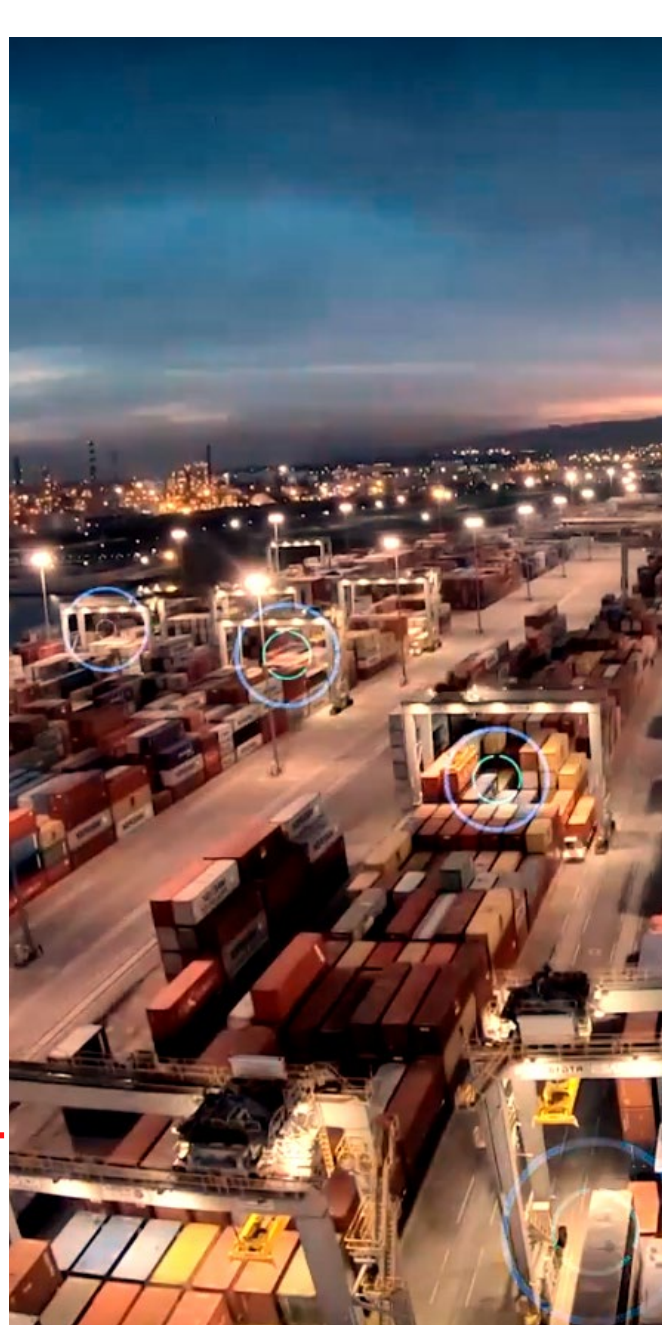

SELECTED REFERENCES



| Year | Customer/Location | Quantity |
|---------|-----------------------|----------|
| 2020/21 | Gulfainer/ Wilmington | 9 |
| 2020 | DPW / Yarimca | 6 |
| 2020 | MINTT / Tangier | 16 |
| 2020 | CTSP / St Petersburg | 5 |
| 2019 | MFT / Malta | 15 |
| 2019 | PTP / Johor | 12 |
| 2019 | PMT / Kuala Tanjung | 12 |



Konecranes is a world-leading group of Lifting Businesses™, serving a broad range of customers, including manufacturing and process industries, shipyards, ports and terminals. Konecranes provides productivity enhancing solutions as well as services for lifting equipment of all makes. The Group has more than 16,000 employees at 600 locations in 50 countries. Konecranes shares are listed on the Nasdaq Helsinki (symbol: KCR).

© 2020 Konecranes. All rights reserved. 'Konecranes', 'Lifting Businesses' and are either registered trademarks or trademarks of Konecranes.

This publication is for general informational purposes only. Konecranes reserves the right at any time, without notice, to alter or discontinue the products and/or specifications referenced herein. This publication creates no warranty on the part of Konecranes, express or implied, including but not limited to any implied warranty or merchantability or fitness for a particular purpose.